

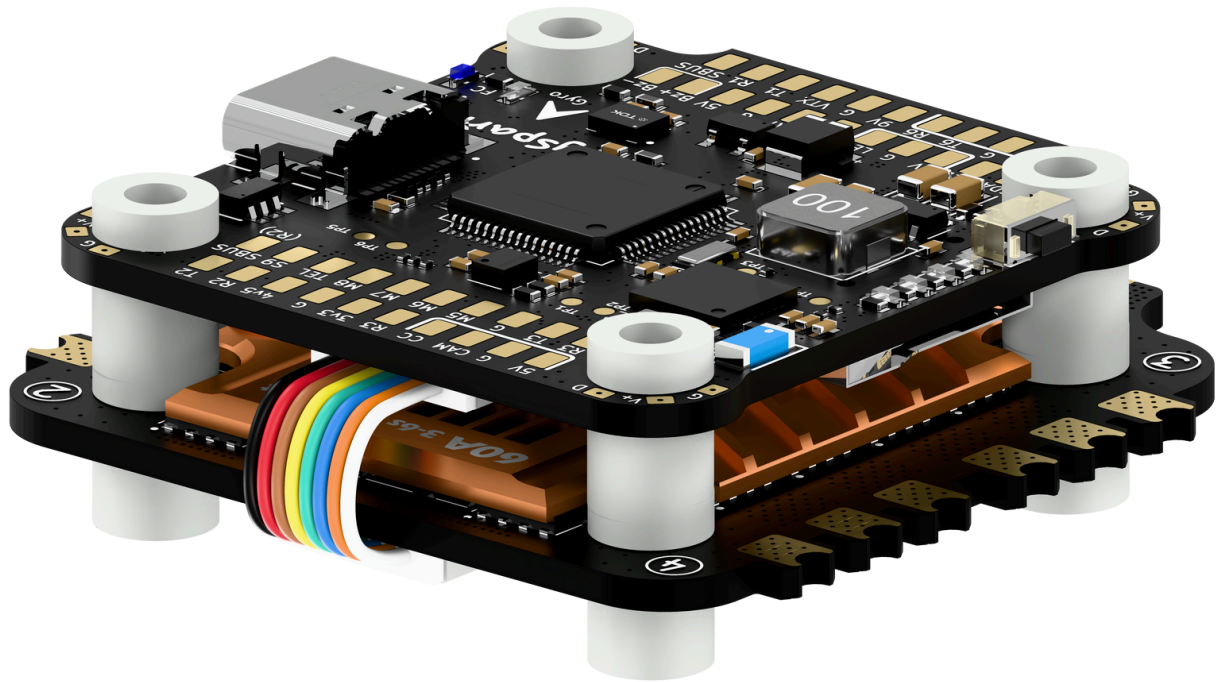

FlySpark F4 V1 BLS 60A Stack



User Manual V1.0

TABLE OF CONTENTS

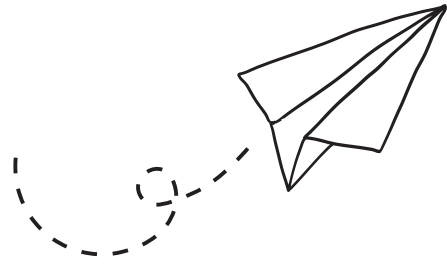

1

OVERVIEW

Specs Overview	1
Dimensions	3
Package	4
FC & ESC Connection	9
Definitions	9

2

FLYSPARK F4 V1 FLIGHT CONTROLLER

Layout	12
FC's Peripheral Connection	14
App & FC Configuration	14
FC Firmware Update	15
specifications	16

3

FLYSPARK BLS 60A 4-IN-1 ESC

Layout	18
Connection with Motors & Power Cable	19
ESC Configuration	22
ESC Firmware Update	24
Specifications	25
	25

Specs Overview

Product Name	FlySpark F4 V1 BLS 60A Stack
AI Features	Sensor Fusion, Adaptive Filtering
Software Support	Betaflight, INAV, Ardupilot, EMU-flight, SkyBrush
ESC Communication	BLHeli_S
Connectivity	Bluetooth & USB-C
Power Input	3-6S LiPo
Dimension	47.8mm(L) x 47.5mm(W) x 18.3mm(H)
Mounting	30.5 x 30.5mm (4mm hole size)
Weight	34g



1 Year Warranty

Dimensions

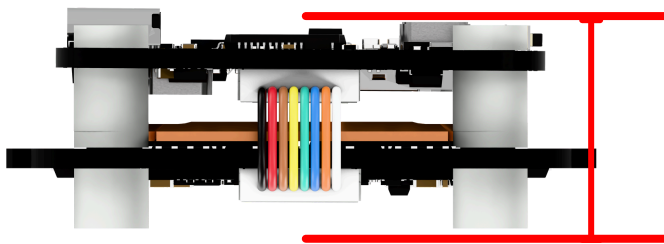
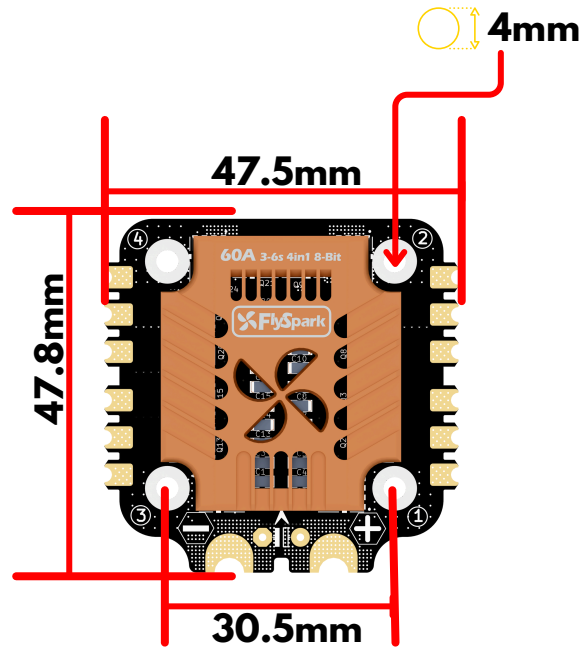
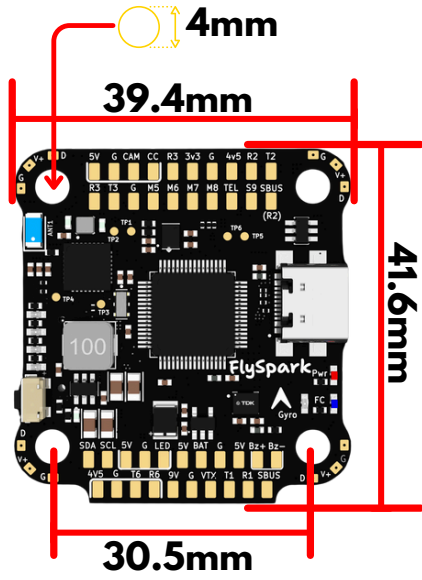
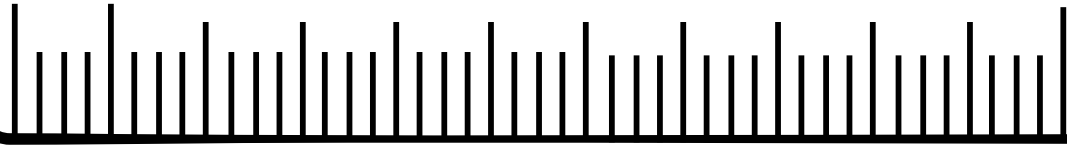



Package

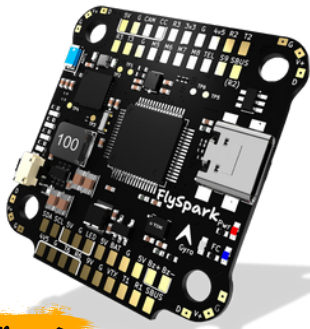

#1

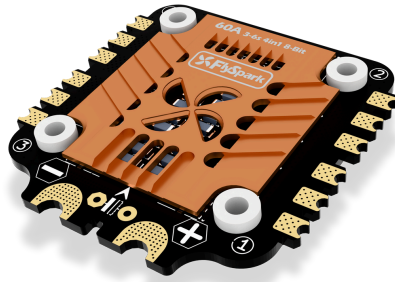

#2



#6



#7



#3

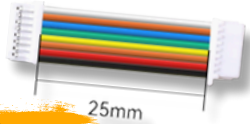

#8



#5



#4



#10



#9



#11



#12

- 1 FlySpark F4 V1 Flight Controller x 1
- 2 FlySpark BLS 60A 4-in-1 ESC x 1
- 3 35V 1000uF Low ESR Capacitor x 1
- 4 M3 Nylon Nut x 4
- 5 M3 silicone O Ring x 4
- 6 M3*8mm Silicone Grommets(for FC) x 4
- 7 M3*8.1mm Silicone Grommets(for ESC) x 4
- 8 SH 1.0mm 25mm-length 8pin Cable(for FC-ESC connection) x 1
- 9 SH 1.0mm 75mm-length 8pin Cable* x 1
- 10 M3*30mm Iner-hexagon Screws x 4
- 11 DJI 6pin Cable(80mm) x 1
- 12 XT60 Power Cable(100mm) x 1

layout

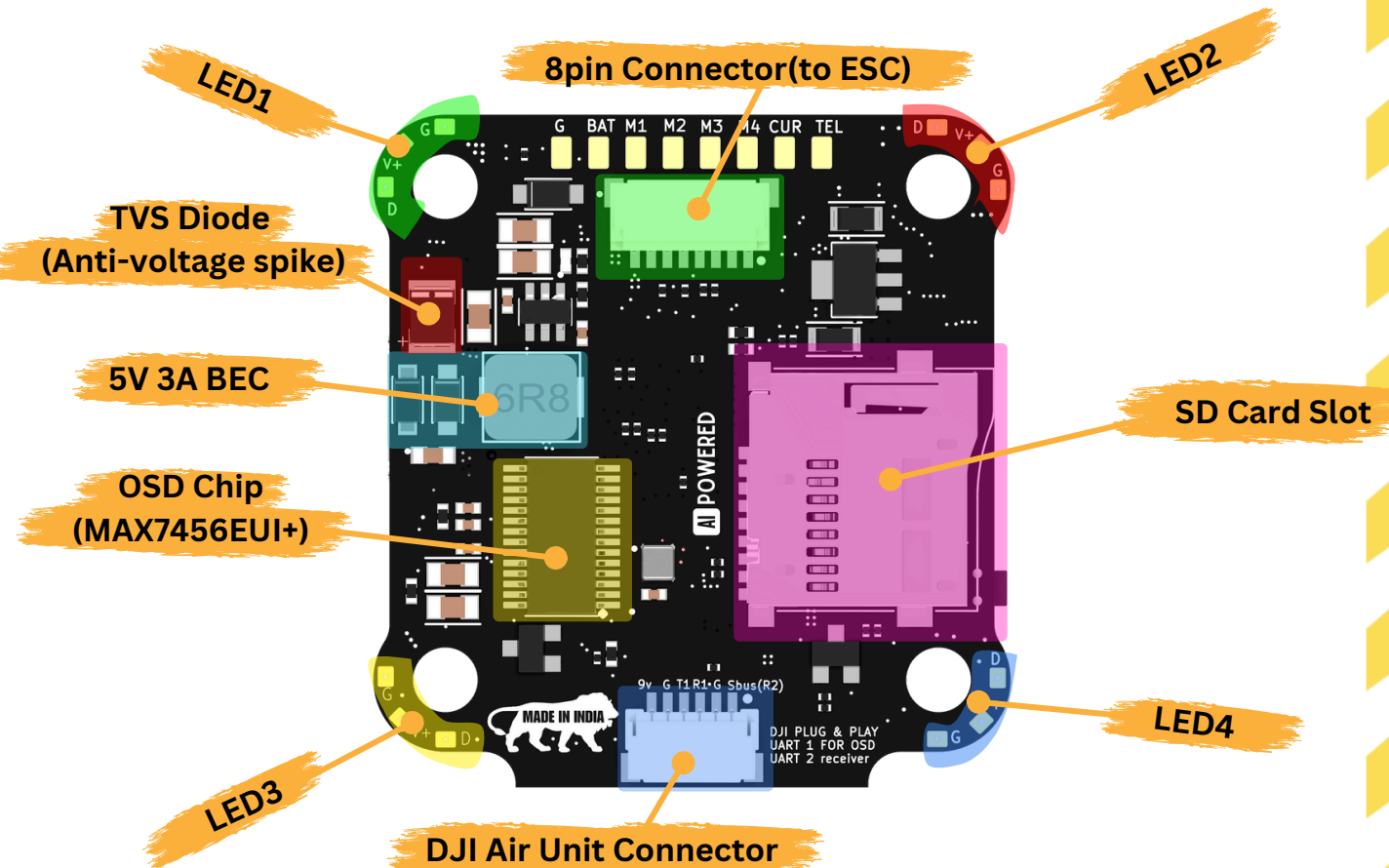
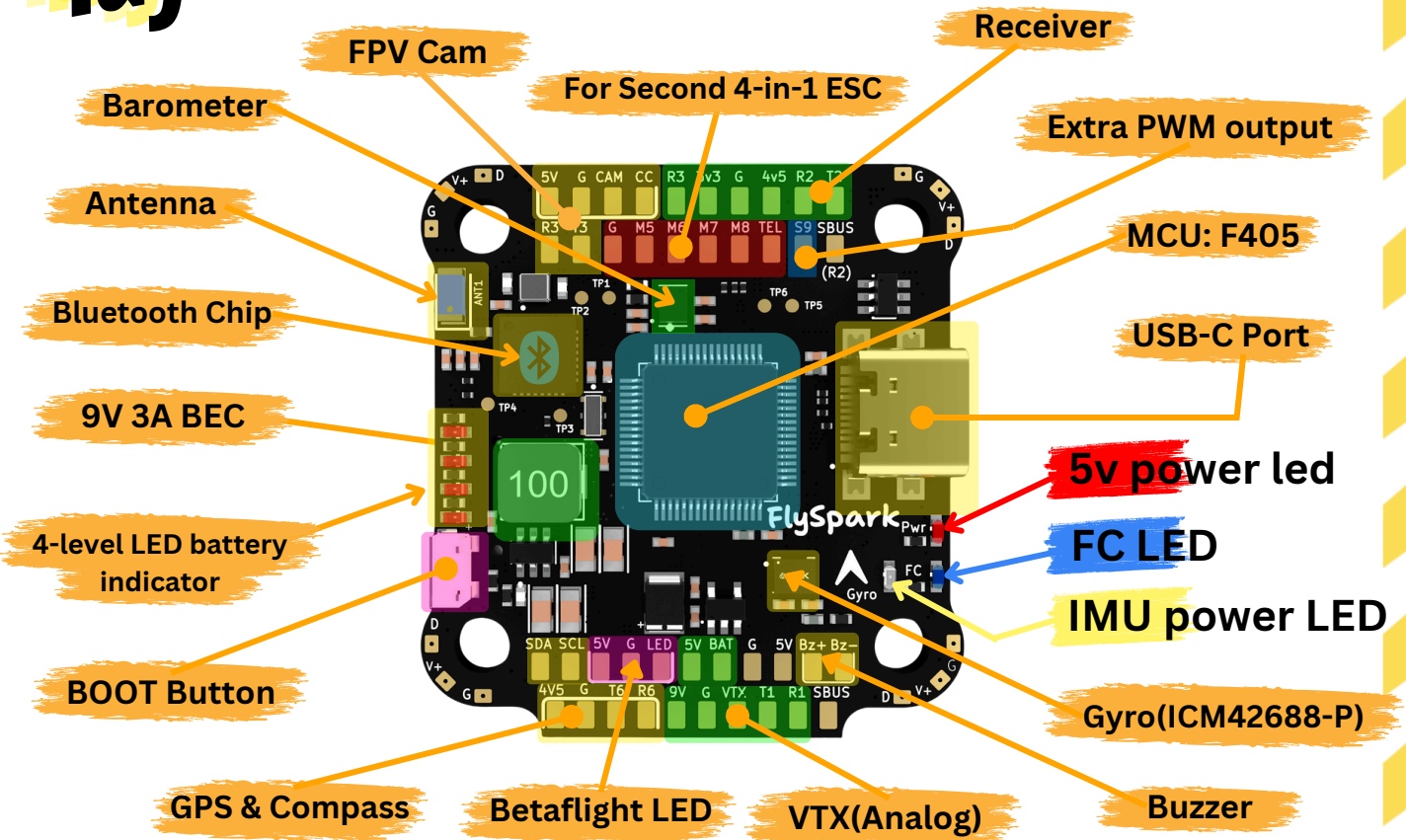

FC Connection diagram

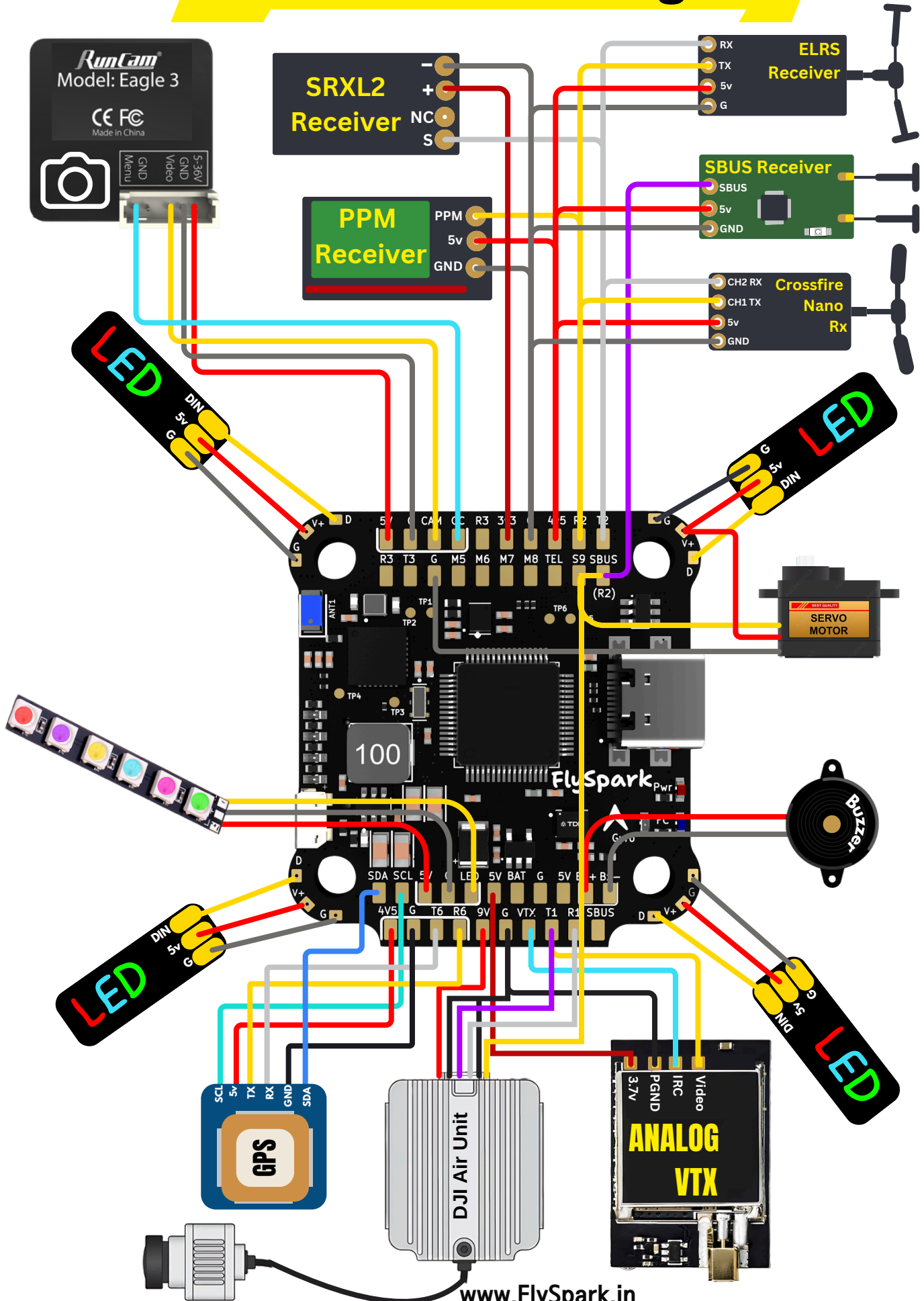

Guide to FC & ESC Connections

Method 1: Using 8-Pin JST Cable

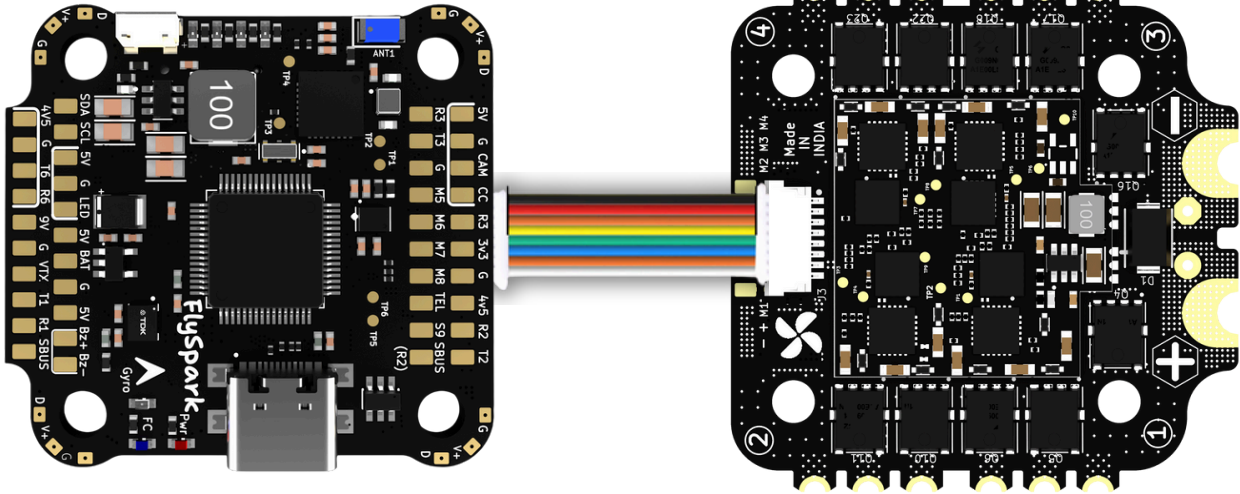

FC

ESC

Method 2: Direct Soldering

Solder 8 wires to the 8 pads on each end, following the pad definitions below

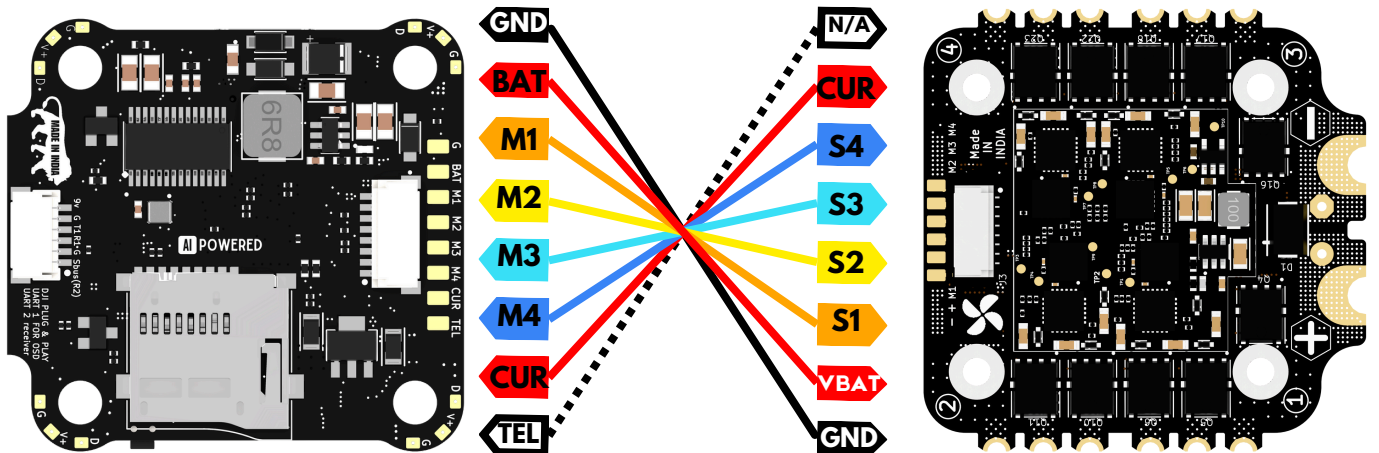

Flight controller specs

Specifications

MCU	STM32F405
IMU(Gyro)	ICM-42688-P
USB Port Type	Type-C
Barometer	Built-in (DPS310XTSA1)
OSD Chip	MAX7456EUI+ chip
BLE Bluetooth	Supported. Used for Flight Controller configuration (MSP should be enabled with Baud rate 115200 on UART4)
WIFI	Not supported
DJI Air Unit Connection Way	Two ways supported: 6-pin connector or direct soldering.
6-pin DJI Air Unit Plug	Supported. Completely compatible with DJI O3/RunCam Link/Caddx Vista/DJI Air Unit V1, no wire is needed to be changed.
Blackbox MicroSD Card Slot	*Betaflight firmware requires the type of the microSD card to be either Standard (SDSC) or High capacity (SDHC) under 32GB, so extended capacity cards (SDXC) are not supported (Many high-speed U3 cards are SDXC). Also the microSD card MUST be formatted with the FAT16 or FAT32 (recommended) format. So, you could use any SD card less than 32GB, but the Betaflight can only recognize 4GB maximum. We suggest you use this 3rd party formatting tool and choose 'Overwrite format' then format your card. Also check out here for the recommended SD cards or buy the tested cards from our store.
Current Sensor Input	Supported. For FlySpark BLS 60A 4-in-1 ESC , please set scale = 400 and Offset = 0.
Power Input	3S - 6S Lipo(Through G, BAT pins/pads from the 8-pin connector or 8-pads on the bottom side)
5V Output	9 groups of 5V output, four +5V pads and 1 BZ+ pad(used for Buzzer) on front side, and 4x LED 5V pads. The total current load is 3A.
9V Output	2 groups of 9V output, one +9V pad on front side and other included in a connector on bottom side. The total current load is 3A.
3.3V Output	Supported. Designed for 3.3V-input receivers. Up to 500mA current load.
4.5V Output	Supported. Designed for receiver and GPS module even when the FC is powered through the USB port. Up to 1A current load.
ESC Signal	M1 - M4 on bottom side and M5-M8 on front side.
UART	6 sets(UART1, UART2, UART3, UART4(Dedicated for Bluetooth connection)), UART5 (Dedicated for ESC telemetry),UART6
ESC Telemetry	UART R5
I2C	Supported. SDA & SCL pads on front side. Used for magnetometer, sonar, etc.
Traditional Betaflight LED Pad	Supported. 5V, G and LED pads on bottom of the front side. Used for WS2812 LED controlled by Betaflight firmware.
Buzzer	BZ+ and BZ- pad used for 5V Buzzer
BOOT Button	Supported. [A]. Press and hold BOOT button and power the FC on at the same time will force the FC to enter DFU mode, this is for firmware flashing when the FC gets bricked.
RSSI Input	Supported. Named as RS on the front side.
Smart Port / F.Port	Not supported
Supported Flight Controller Firmware	BetaFlight(Default), INAV, EMU-Flight Ardupilot, skybrush, omnibus F4
Firmware Target Name	FLYSPARKF4v1
Mounting	30.5 x 30.5mm(4mm hole diameter)
Dimension	41.6(L) x 39.4(W) x 7.8(H)mm
Weight	10.5g

Cable Connection vs DJI O3 Air Unit

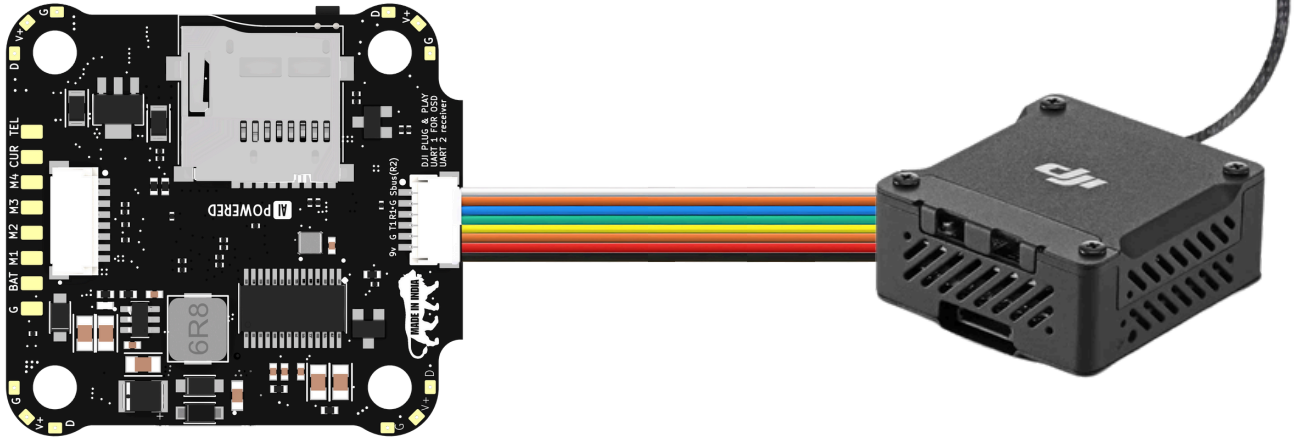

Use 6-pin cable comes with the O3 Air Unit

Cable Connection with DJI Air Unit V1

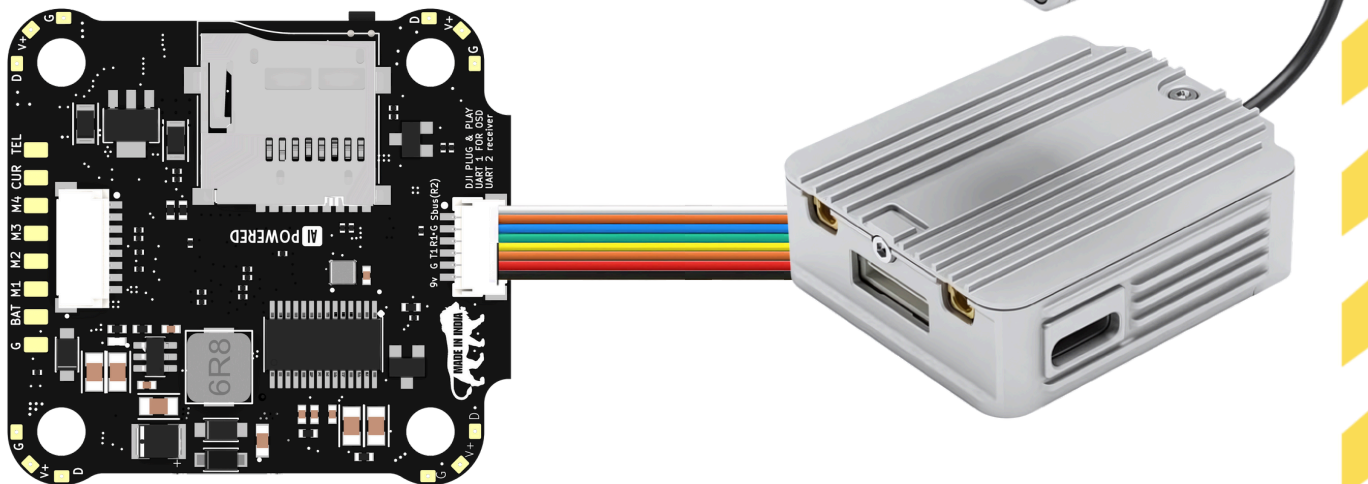

Use 6-pin cable comes with the FlySpark F4 V1 BLS 60A Stack

App & FC Configuration

COMING SOON



www.FlySpark.in/app

FC Firmware Update

To update the firmware for your FlySpark F4 V1 flight controller, please follow these steps:

- 1. Connect the Flight Controller to Your PC:**
 - Use a USB cable to connect the FlySpark F4 V1 flight controller to your PC.
- 2. Open Betaflight / INAV Configurator:**
 - Launch the Betaflight Configurator or INAV Configurator on your PC. For this guide, we'll use Betaflight Configurator as an example.
- 3. Navigate to Firmware Flashing:**
 - In the Betaflight Configurator, navigate to the 'Firmware Flashing' page.
- 4. Select Target and Flash Firmware:**
 - Choose the target firmware for 'FlySpark F4 V1' from the dropdown menu.
 - Initiate the firmware flashing process.

Note: The FlySpark F4 V1 flight controller does not support wireless firmware flashing. It must be performed using a USB connection to your PC.

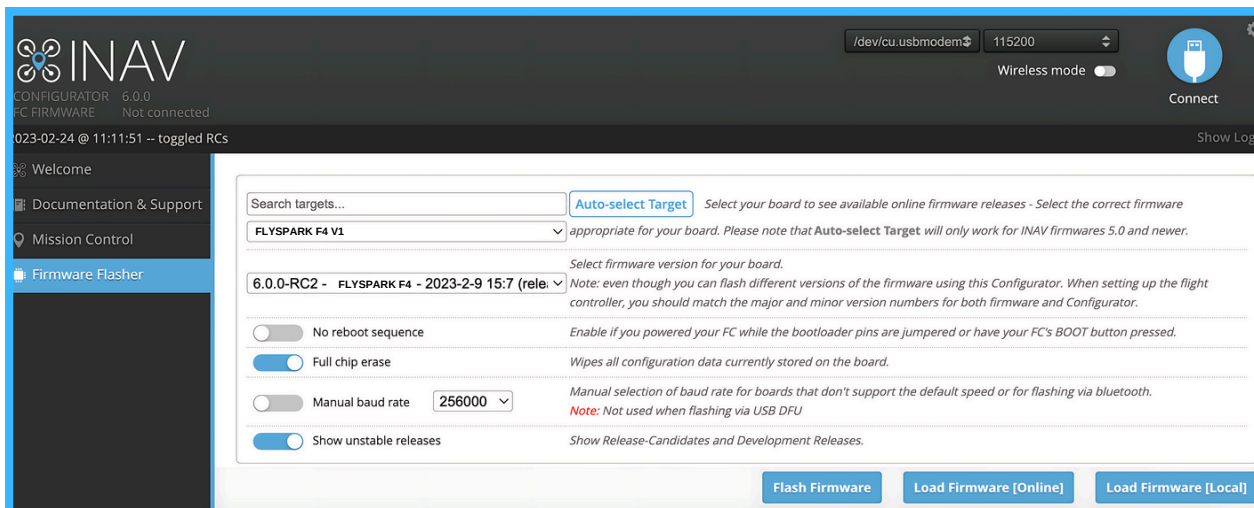
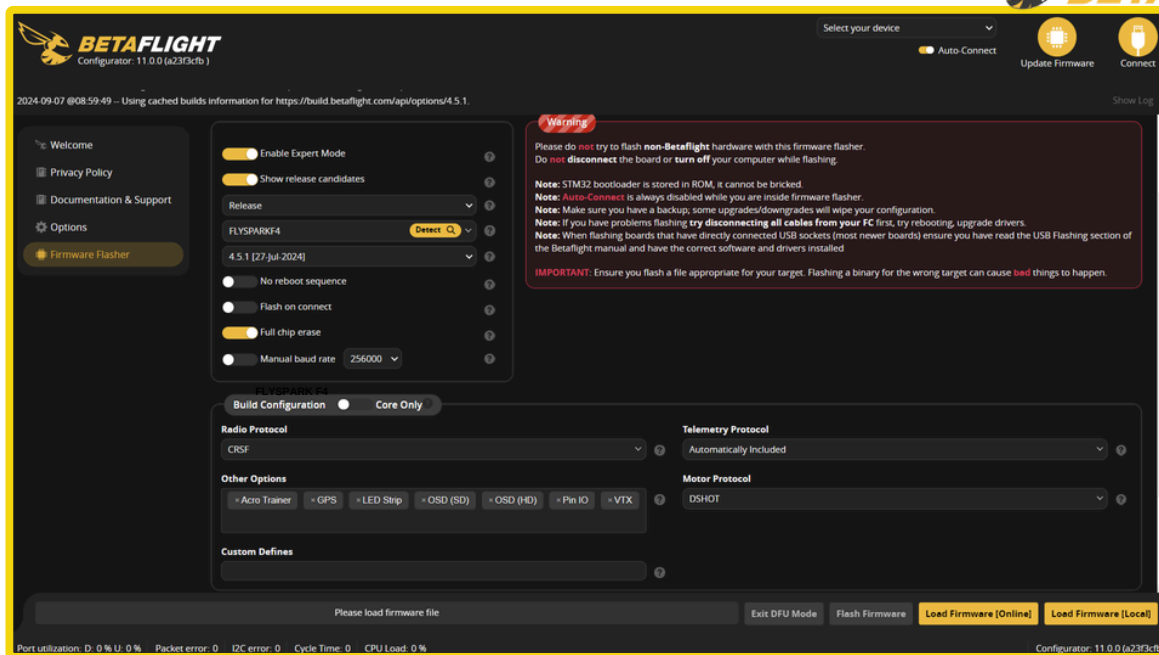

FlySpark BLS 60A 4-in-1 ESC

layout

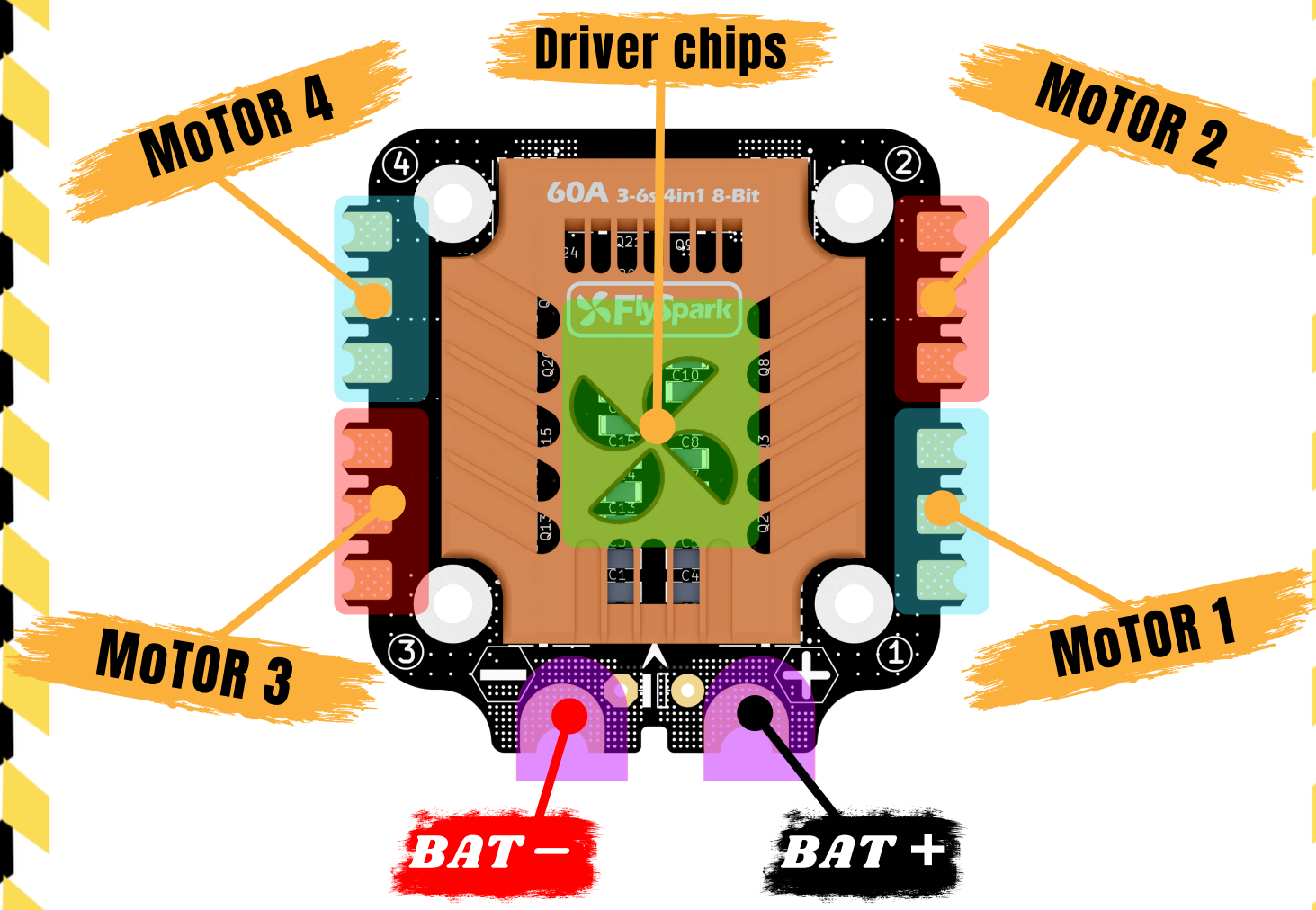

8pin connector(to FC)

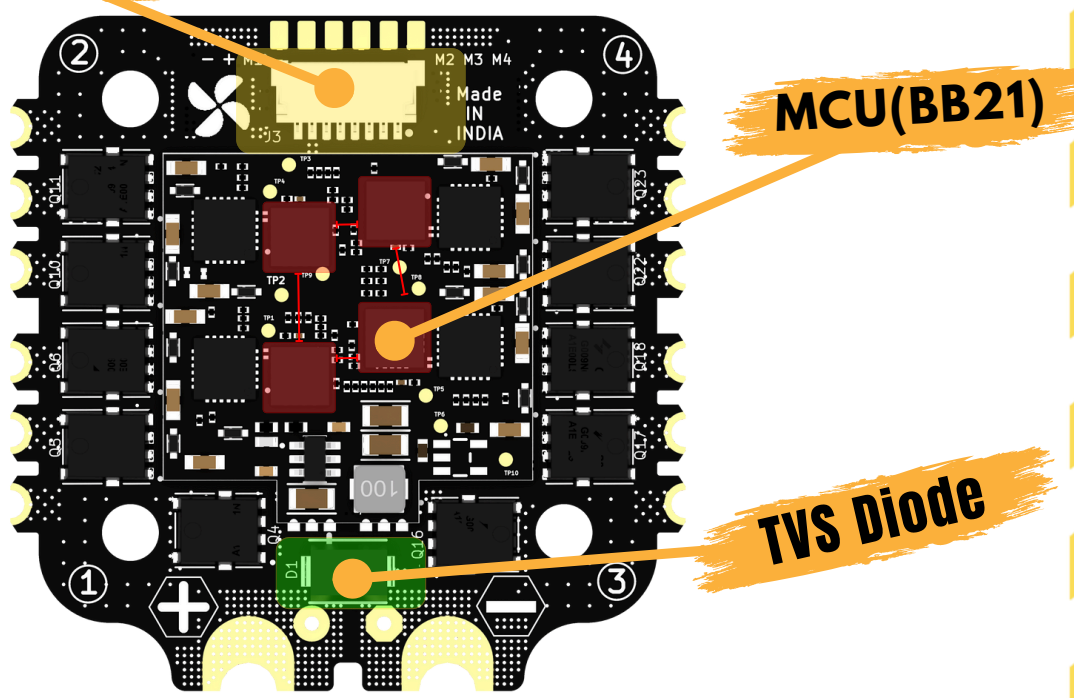

Connection with Motors & Power Cable

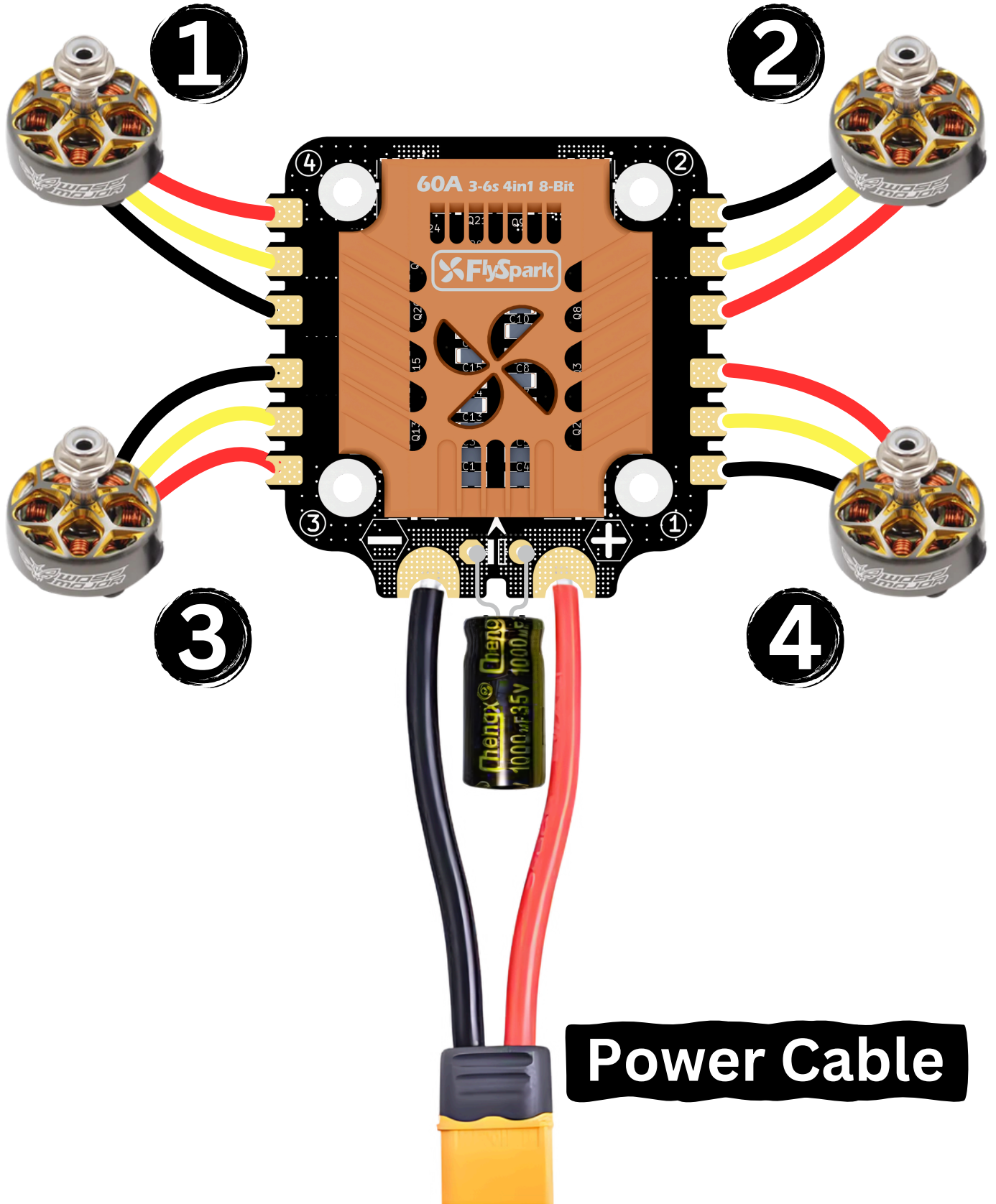

ESC Specs

FlySpark F4 V1 BLS 60A Stack

Firmware	BLHeli_S JH50
ESC Protocol	DSHOT300/600
Wireless Configuration	Full Configuration Supported in the FlySpark app
PC Configurator Download Link	https://esc-configurator.com/
Continuous Current	60A*4
Burst Current	80A(10 sec)
TVS Protective diode	Yes
External Capacitor	1000uF Low ESR Capacitor(In the package)
ESC Telemetry	Not supported
Power Input	3-6S LiPo
Power Output	VBAT
Dimension	47.8mm(L) x 47.5mm(W) x 18.3mm(H)
Mounting	30.5 x 30.5mm (4mm hole size)
Weight	24g*

ESC Firmware Update

This 8-bit 50A ESC comes pre-loaded with BLHeliS firmware but can also be flashed to Bluejay firmware, offering RPM filtering and Bi-directional Dshot support. Follow these steps to update the firmware:

1. Prepare Your Drone:
 - ▶ Remove all propellers from your drone for safety.
2. Connect ESC to Flight Controller:
 - ▶ Ensure the flight controller is properly connected to the ESC, then power up the drone. This step ensures the ESC initializes correctly.
3. Connect to PC:
 - ▶ Use a USB Type-C cable to connect the flight controller to your computer.
4. Access Firmware Configuration:
 - ▶ Open the Chrome browser and visit: www.esc-configurator.com
5. Flashing Steps:
 - ▶ Follow the firmware flashing steps displayed on the configurator website. Ensure you select the appropriate options for flashing to Bluejay firmware.

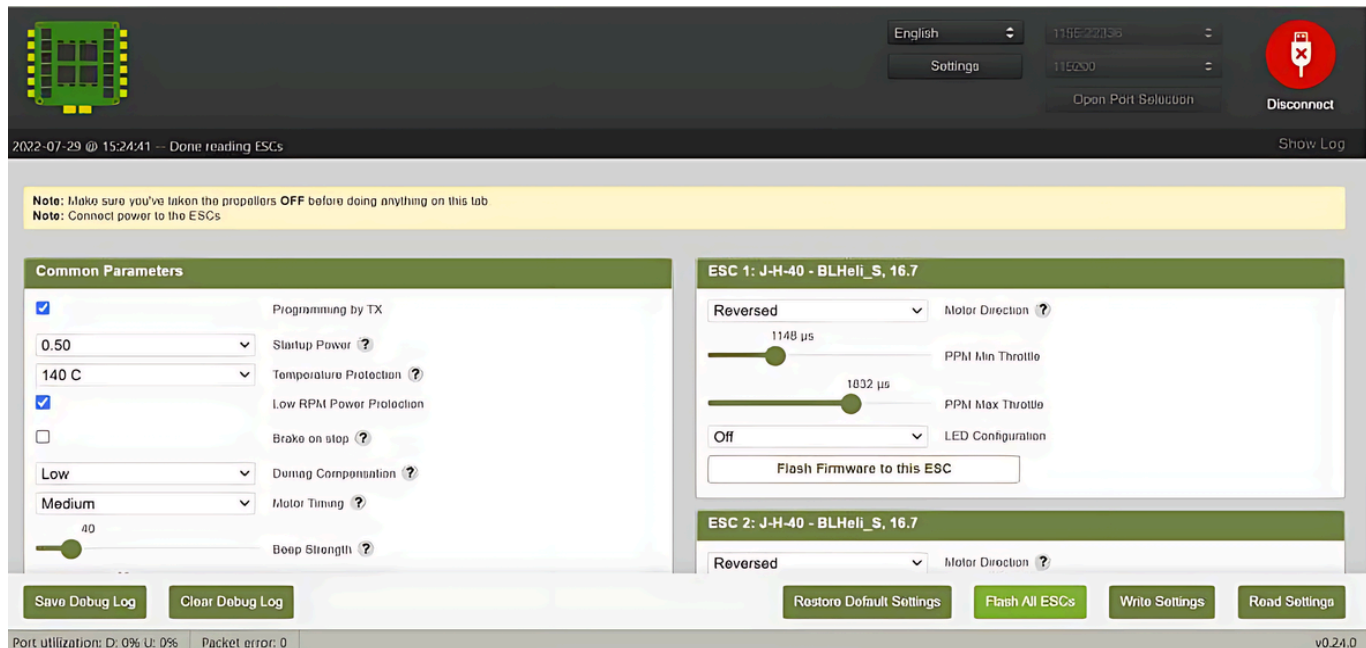

The screenshot shows the ESC Configurator website interface. At the top, there is a navigation bar with a language dropdown set to 'English', a 'Settings' button, and a 'Disconnect' button. Below the navigation bar, there is a status bar showing the date and time '2022-07-29 @ 15:24:41' and the message 'Done reading ESCs'. The main content area is divided into two sections: 'Common Parameters' and 'ESC 1: J-H-40 - BLHeli_S, 16.7'. The 'Common Parameters' section includes checkboxes for 'Programming by TX', 'Low RPM Power Protection', and 'Brake on stop', along with dropdown menus for 'Startup Power' (0.50), 'Temperature Protection' (140 C), 'Damage Compensation' (Low), and 'Motor Timing' (Medium), and a slider for 'Beep Strength' (40). The 'ESC 1' section includes a 'Reversed' dropdown, a 'Motor Direction' dropdown, a 'PPM Min Throttle' slider (1148 µs), a 'PPM Max Throttle' slider (1832 µs), and an 'LED Configuration' dropdown (Off). A 'Flash Firmware to this ESC' button is located below the sliders. At the bottom of the interface, there are buttons for 'Save Debug Log', 'Clear Debug Log', 'Restore Default Settings', 'Flash All ESCs', 'Write Settings', and 'Load Settings'. The status bar at the very bottom shows 'Port utilization: D: 0% U: 0%' and 'Packet error: 0'.

- CAUTIONS:**
- **PROPELLERS OFF: REMOVE ALL PROPELLERS.**
 - **SECURE CONNECTION: ENSURE SECURE ESC CONNECTION.**
 - **FOLLOW STEPS: FOLLOW FLASHING INSTRUCTIONS CAREFULLY.**
 - **STABLE POWER: ENSURE STABLE POWER SUPPLY.**

